

XCKP2121G11

Limit switch, Limit switches XC Standard, XCKP, thermoplastic roller lever plung. Hor, 1NC+1 NO, snap, Pg11



Main

| | |
|-------------------------------|--|
| Range of product | Telemecanique Limit switches XC Standard |
| Series name | Standard format |
| Product or component type | Limit switch |
| Device short name | XCKP |
| Sensor design | Compact form E conforming to CENELEC EN 50047 |
| Body type | Fixed |
| Head type | Plunger head |
| Material | Plastic |
| Body material | Plastic |
| Head material | Zamak |
| Fixing mode | By the body |
| Movement of operating head | Linear |
| Type of operator | Spring return roller lever plunger thermoplastic |
| Type of approach | Lateral approach, 1 direction |
| Number of poles | 2 |
| Contacts type and composition | 1 NC + 1 NO |
| Contact operation | Snap action |

Complementary

| | |
|--|--|
| Switch actuation | By 30° cam |
| Electrical connection | Screw-clamp terminals, clamping capacity: 1 x 0.34...2 x 1.5 mm ² |
| Cable entry | 1 entry tapped for Pg 11 cable gland |
| Contacts insulation form | Zb |
| Positive opening | With |
| Positive opening minimum force | 18 N |
| Minimum force for tripping | 6 N |
| Maximum actuation speed | 1 m/s |
| Repeat accuracy | 0.1 mm on the tripping points with 1 million operating cycles |
| Contact code designation | A300, AC-15 (Ue = 240 V), Ie = 3 A, Ithe = 10 A conforming to IEC 60947-5-1 appendix A Q300, DC-13 (Ue = 250 V), Ie = 0.27 A conforming to IEC 60947-5-1 appendix A |
| [Ui] rated insulation voltage | 300 V conforming to UL 508 500 V (pollution degree 3) conforming to IEC 60947-1 300 V conforming to CSA C22.2 No 14 |
| Maximum resistance across terminals | 25 MOhm conforming to IEC 60255-7 category 3 |
| [Uimp] rated impulse withstand voltage | 6 kV conforming to IEC 60664 6 kV conforming to IEC 60947-1 |
| Short-circuit protection | 10 A cartridge fuse, type gG |
| Electrical durability | 5000000 Cycles, DC-13, 120 V, 4 W, operating rate <60 cyc/mn, load factor: 0.5 conforming to IEC 60947-5-1 appendix C 5000000 Cycles, DC-13, 24 V, 10 W, operating rate <60 cyc/mn, load factor: 0.5 conforming to IEC 60947-5-1 appendix C 5000000 cycles, DC-13, 48 V, 7 W, operating rate <60 cyc/mn, load factor: 0.5 conforming to IEC 60947-5-1 appendix C |
| Mechanical durability | 15000000 cycles |
| Width | 31 mm |
| Height | 65 mm |

| | |
|-------------------------------|------------------------|
| Depth | 30 mm |
| Net weight | 0.105 kg |
| Terminals description ISO n°1 | (13-14)NO (21-22)NC |

Environment

| | |
|---------------------------------------|---|
| Shock resistance | 50 gn for 11 ms conforming to IEC 60068-2-27 |
| Vibration resistance | 25 gn (f= 10...500 Hz) conforming to IEC 60068-2-6 |
| IP degree of protection | IP66 conforming to IEC 60529 IP67 conforming to IEC 60529 |
| IK degree of protection | IK04 conforming to IEC 62262 |
| Electrical shock protection class | Class II conforming to IEC 61140 Class II conforming to NF C 20-030 |
| Ambient air temperature for operation | -25...70 °C |
| Ambient air temperature for storage | -40...70 °C |
| Protective treatment | TC |
| Product certifications | CSA[RETURN]JUL[RETURN]CCC |
| Standards | CSA C22.2 No 14 IEC 60947-5-1 IEC 60947-5-1 IEC 60204-1 UL 508 IEC 60204-1 |

Packing Units

| | |
|------------------------------|-----------|
| Unit Type of Package 1 | PCE |
| Number of Units in Package 1 | 1 |
| Package 1 Height | 3.500 cm |
| Package 1 Width | 3.900 cm |
| Package 1 Length | 10.200 cm |
| Package 1 Weight | 85.000 g |
| Unit Type of Package 2 | S02 |
| Number of Units in Package 2 | 77 |
| Package 2 Height | 15.000 cm |
| Package 2 Width | 30.000 cm |
| Package 2 Length | 40.000 cm |
| Package 2 Weight | 7.113 kg |

Offer Sustainability

| | |
|--|---|
| Sustainable offer status | Green Premium product |
| California proposition 65 | WARNING: This product can expose you to chemicals including: Diisononyl phthalate (DINP), which is known to the State of California to cause cancer, and Di-isodecyl phthalate (DIDP), which is known to the State of California to cause birth defects or other reproductive harm. For more information go to www.P65Warnings.ca.gov |
| For all Reach Rohs enquiries contact us at | sustainability@tesensors.com |

Contractual warranty

| | |
|----------|-----------|
| Warranty | 18 months |
|----------|-----------|

Dimensions

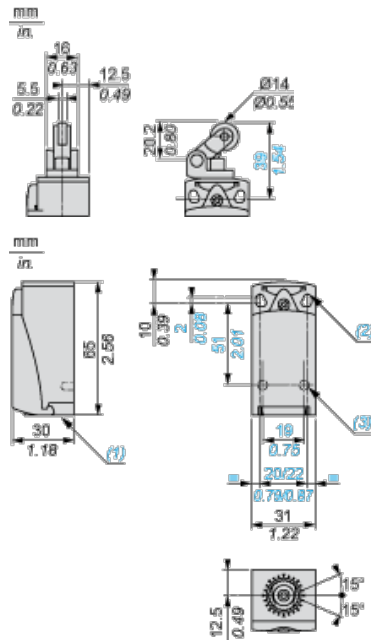

- (1) Tapped entry for Pg 11 cable gland
- (2) 2 elongated holes $\varnothing 4.3 \times 6.3$ mm on 22 mm centres, 2 holes $\varnothing 4.3$ on 20 mm centres.
- (3) 2 x $\varnothing 3$ holes for support studs, depth 4 mm.

Mounting with Cable Entry

Position of Cable Gland

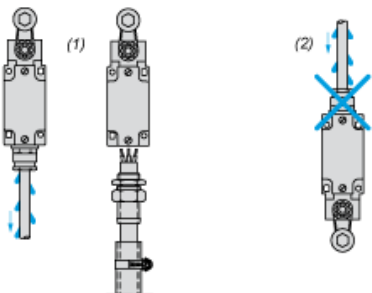

- (1) Recommended
- (2) To be avoided

Mounting with Rotary Heads and Levers

Type of Cam

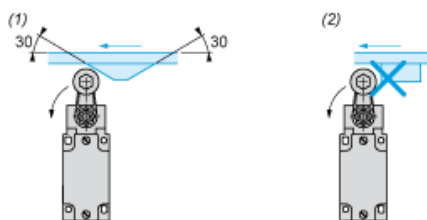

- (1) Recommended
- (2) To be avoided

Setting-up with Head ZCE01 and ZCE09

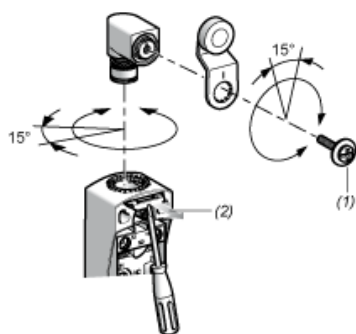

- (1) Tightening torque (Min : 1) (Max : 1.5)
- (2) Tightening torque (Min : 0.8) (Max : 1.2)

Wiring Diagram

2-pole NC + NO Snap Action

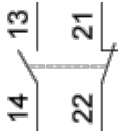

Characteristics of Actuation

Switch Actuation by 30° Cam

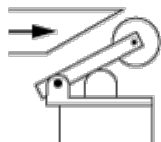

Functionnal Diagram

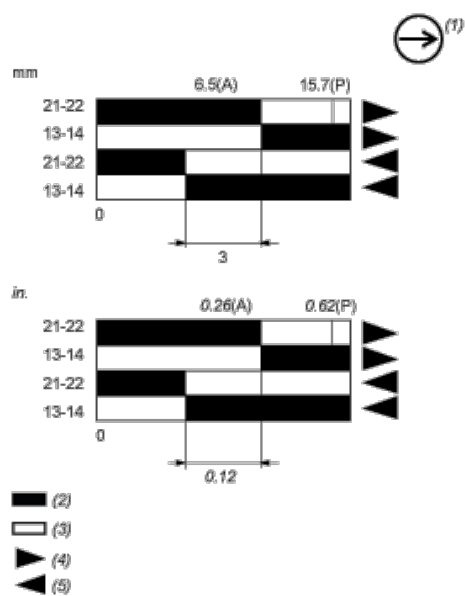

- (P) Positive opening point
- (A) Cam displacement
- (1) NC contact with positive opening operation
- (2) Closed
- (3) Open
- (4) Tripping
- (5) Resetting