

## Introduction



In combination with the corresponding safety modules, the sensors of the ST D series are suitable for the monitoring of protective devices on machines without inertia and allow the system in which they are used to reach a safety category up to SIL 3 acc. to EN 62061 as well as up to PL e and Category 4 acc. to EN ISO 13849-1. These sensors use RFID (Radio Frequency IDentification) technology and provide high protection against possible manipulation thanks to the uniqueness of the codes transmitted by the actuator. Because they have no mechanical elements, they guarantee a long service life even in applications with frequent operating cycles and under harsh environmental conditions.

## Maximum safety with a single device

**PL e + SIL 3** The sensors of the ST D series are constructed with redundant electronics. As a result, the maximum PL e and SIL 3 safety levels can still be achieved through the use of a single device on a guard. This avoids expensive wiring in the field and allows faster installation. Inside the control cabinet, the two electronic safety outputs must be connected to a module suitable for managing devices with solid state outputs, or to a safety PLC.

## Series connection of multiple sensors

**PL e + SIL 3** One of the most important features of the ST D series from Pizzato Elettrica is the possibility of connecting up to 32 sensors in series, while still maintaining the maximum safety level (PL e) laid down in EN 13849-1.

This connection type is permissible in safety systems which have a safety module at the end of the chain that monitors the outputs of the last ST sensor.

The fact that the PL e safety level can be maintained even with 32 sensors connected in series demonstrates the extremely secure structure of each sensor of the ST series.

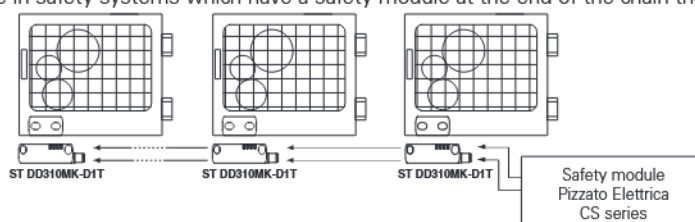

## Series connection with other devices

**PL e + SIL 3** The ST D series features two safety inputs and two safety outputs, which can be connected in series with other Pizzato Elettrica safety devices. This option allows the creation of safety chains containing various devices. For example, stainless steel safety hinges (HX BEE1 series), transponder sensors (ST series) and door lock sensors (NG or NS series) can be connected in series while still maintaining the maximum PL e and SIL 3 safety levels.

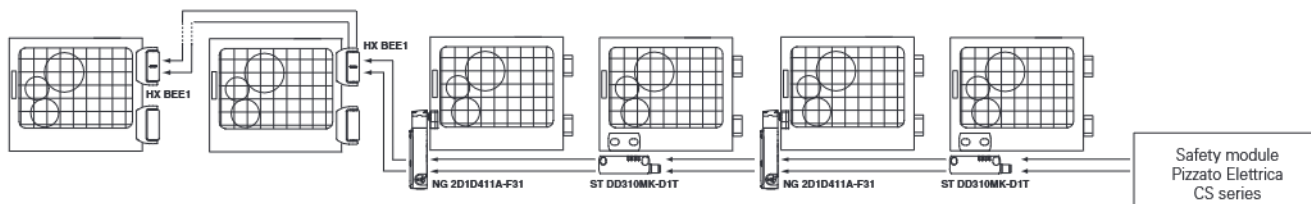

## High level coded actuators



The ST D series is provided with an electronic system based on RFID technology to detect the actuator. This allows to provide each actuator with different coding and makes it impossible to tamper with a device by using another actuator of the same series. Millions of different coding combinations are possible for the actuators. They are therefore classified as high level coded actuators, according to EN ISO 14119.

## Protection degrees IP67 and IP69K

**IP69K**  
**IP67**

These devices are designed to be used under the toughest environmental conditions, and they pass the IP67 immersion test acc. to EN 60529. They can therefore be used in all environments where the maximum degree of protection is required for the housing. Due to

their special design, these devices are suitable for use in equipment subjected to cleaning with high pressure hot water jets. These devices meet the IP69K test requirements according to ISO 20653 (water jets with 100 bar and 80°C).

## Wide actuation range

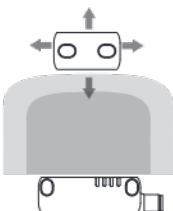

By utilising the properties of RFID technology, the sensors of the ST D series have a wide actuation range, making them very well suited for applications with large tolerances or where mechanical properties change over time.

## Actuation from many directions

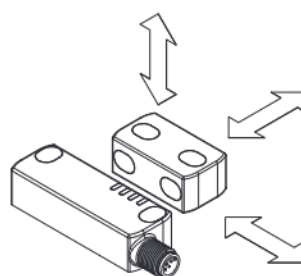

The sensors of the ST D series from Pizzato Elettrica were designed to be activated from various directions, thereby providing the customer with maximum flexibility when positioning the sensors on the guards. Furthermore, the SM D•T actuator can be secured in two mutually orthogonal directions.



### Programmability

Pizzato Elettrica supplies a programmable version of the ST D series sensors. With a simple and brief operation, the sensor can be programmed to recognise the code of a new actuator.

By activating a special input, the sensor is switched to a safe state, during which it waits for a new code to be accepted. As the actuator approaches, the ST D sensor performs a number of checks on the code being received, whereby the code must adhere to certain parameters of RFID technology.

If the checks are successful, the sensor uses LEDs to signal the successful completion of the procedure.

After programming has been completed, the sensor only recognises the code of the last programmed actuator, thereby preserving the safety level and the reliability of the system in which it is installed.

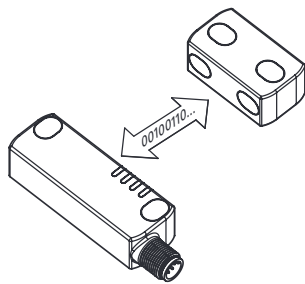

### Laser engraving

All devices are marked using a dedicated indelible laser system. These engravings are therefore suitable for extreme environments too. Thanks to this system that does not use labels, the loss of plate data is prevented and a greater resistance of the marking is achieved over time.



### Short signal propagation delay

One of the main features of the ST D sensors is the short signal propagation time of approx. 7 ms after deactivation of the inputs.

This short signal propagation time is particularly advantageous for sensors connected in series.

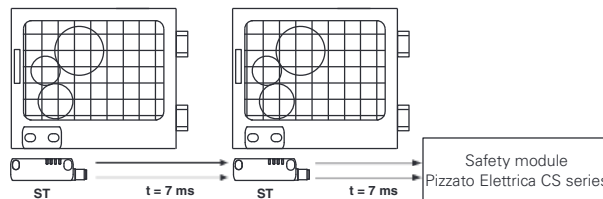

### Stainless steel fixing plates

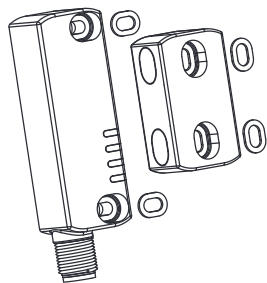

The stainless-steel fixing plates for the ST D sensors not only protect the mounting eyes during installation on surfaces that are not perfectly flat, they also help the sensor better withstand mechanical loads. As a result, the system is safer and more reliable.

### Protection against tampering

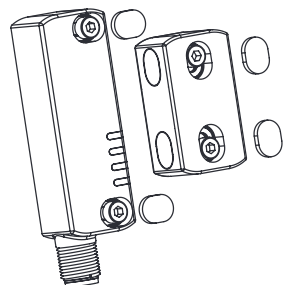

Each sensor and actuator of the ST D series is supplied complete with snap-on protection caps to be applied on the holes of the fixing screws. Not only do the caps prevent dirt from accumulating and simplify cleaning, they also block access to the fastening screws of the actuator. As a result, standard screws can be used instead of tamper-proof screws.

### Insensitivity to dirt

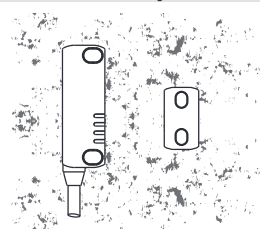

The sensors are completely sealed and retain their safety characteristics even in the presence of dirt or deposits (not ferromagnetic material). This characteristic, combined with the design without recesses, makes them particularly suitable for use in the food industry.

### Four LEDs for immediate diagnosis

As the LEDs have been designed for quick immediate diagnosis, the status of each input and output is highlighted by one specific LED. By knowing which device is active and which door is open, it is possible to quickly identify an interruption in the safety chain as well as any internal device errors. All of this at a glance, without needing to decode complex flashing sequences.



### Versions with increased actuation distance

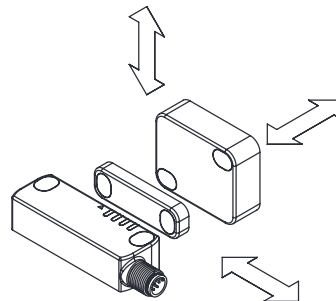

In addition to the standard actuation distance of 12 mm, sensors with an actuation distance of 20 mm are also available. The increased actuation distance of the sensors is ideal for installation situations in which it is not possible to ensure that the actuator approaches the sensor in a precise and stable manner.

### New compact actuators

In addition to the standard actuators, the new compact actuators SM L•T are now available to order; these actuators have a single mounting direction (frontal) and maintain the same actuation distance of 12 mm as the actuator SM D•T.

Due to the reduced thickness (just 7 mm), they can be installed in all applications with restricted space conditions and thereby enable use of RFID technology, even with guards of small dimensions.

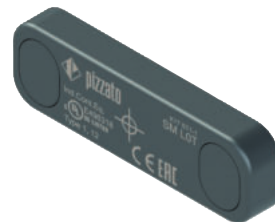

### External device monitoring

**EDM** On request, the switch can be supplied with EDM function (External Device Monitoring). In this case, the switch itself checks the proper function of the devices connected to the safety outputs. These devices (usually relays or safety contactors) must send a feedback signal to the EDM input, which checks that the received signal is consistent with the state of the safety outputs.

### Extended supply voltage range

In addition to the standard 24 Vdc supply voltage, the ST D series sensors are available with an extended supply voltage of 12 ... 24 Vdc (articles ST D•••1••). This characteristic makes them particularly suitable for use in the automotive sector, in machines powered by common battery systems, and both in light and heavy vehicles.

## Selection diagram

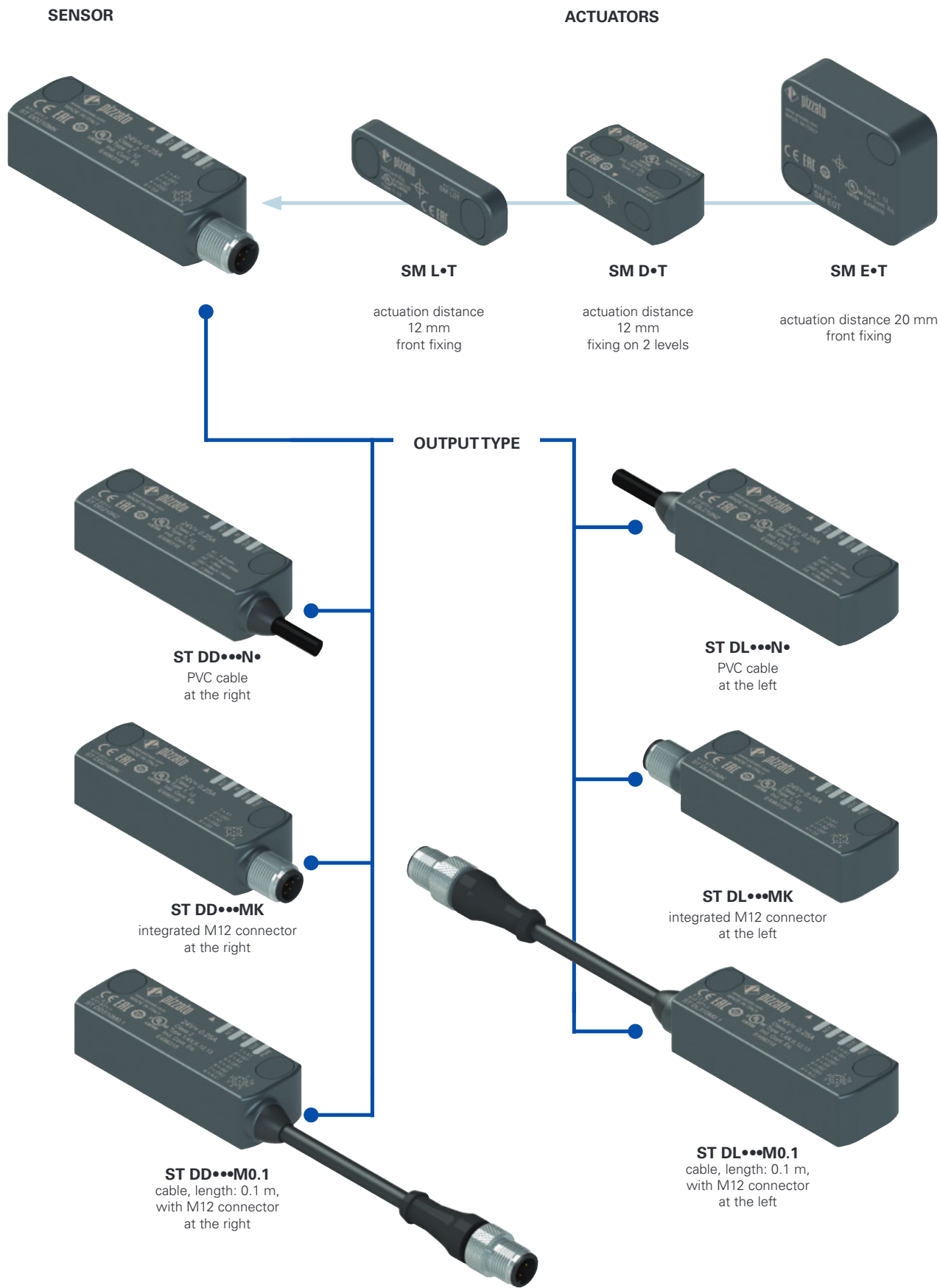

● product option  
→ Sold separately as accessory



**Attention!** The feasibility of a code number does not mean the effective availability of a product. Please contact our sales office.

### Code structure for sensor with actuator

# ST DD420N2-D1T

#### Output direction, connections

<b>D</b>	output at the right
<b>L</b>	output at the left

#### Inputs and outputs

	OS safety outputs	O3 signalling outputs	IS safety inputs	I3 programming inputs	EDM inputs
<b>21</b>	2	1	-	-	-
<b>31</b>	2	1	2	-	-
<b>42</b>	2	1	2	1	-
<b>51</b>	2	1	2	-	1
<b>61</b>	2	1 (inverted)	-	-	-
<b>71</b>	2	1 (inverted)	2	-	-
<b>82</b>	2	1 (inverted)	2	1	-

**Note:** versions 21, 31, 51, 61, 71 are only supplied together with an actuator.

#### Supply voltage

<b>0</b>	24 Vdc
<b>1</b>	12 ... 24 Vdc

#### Cable or connector type

<b>N</b>	PVC cable, IEC 60332-1-2 oil resistant (standard)
<b>H</b>	PUR cable, halogen free (not available with versions ST D•2•••• and ST D•6••••)
<b>M</b>	M12 connector

#### Actuator

<b>D0T</b>	standard actuator low level of coding the sensor recognises any type D0T actuator
<b>D1T</b>	standard actuator high level of coding the sensor recognises one single type D1T actuator
<b>E0T</b>	Large actuator low level of coding the sensor recognises any type E0T actuator
<b>E1T</b>	Large actuator high level of coding the sensor recognises one single type E1T actuator
<b>L0T</b>	miniaturized actuator low level of coding the sensor recognises any type L0T actuator
<b>L1T</b>	miniaturized actuator high level of coding the sensor recognises one single type L1T actuator

#### Connection type

<b>0.1</b>	cable, length: 0.1 m, with M12 connector
<b>0.5</b>	cable, length: 0.5 m
...	...
<b>2</b>	cable, length: 2 m (standard)
...	...
<b>10</b>	cable, length: 10 m
<b>K</b>	integrated M12 connector

**Attention!** The feasibility of a code number does not mean the effective availability of a product. Please contact our sales office.

### Code structure for single sensor

# ST DD420N2

#### Output direction, connections

<b>D</b>	output at the right
<b>L</b>	output at the left

#### Inputs and outputs

	OS safety outputs	O3 signalling outputs	IS safety inputs	I3 programming inputs
<b>42</b>	2	1	2	1
<b>82</b>	2	1 (inverted)	2	1

#### Supply voltage

<b>0</b>	24 Vdc
<b>1</b>	12 ... 24 Vdc

#### Connection type

<b>0.1</b>	cable, length: 0.1 m, with M12 connector
<b>0.5</b>	cable, length: 0.5 m
...	...
<b>2</b>	cable, length: 2 m (standard)
...	...
<b>10</b>	cable, length: 10 m
<b>K</b>	integrated M12 connector

#### Cable or connector type

<b>N</b>	PVC cable, IEC 60332-1-2 oil resistant (standard)
<b>H</b>	PUR cable, halogen free (not available with versions ST D•2•••• and ST D•6••••)
<b>M</b>	M12 connector

**Attention!** Individual sensors are initially programmed with the code of the actuators with low coding level •0T.  
**Attention!** The feasibility of a code number does not mean the effective availability of a product. Please contact our sales office.

### Code structure for actuator

# SM D1T

#### Design and actuation distance

<b>D</b>	standard actuator actuation distance 12 mm
<b>E</b>	large actuator actuation distance 20 mm
<b>L</b>	miniaturized actuator actuation distance 12 mm

#### Actuator

<b>0T</b>	low level coded actuator the sensor recognises any type •0T actuator
<b>1T</b>	high level coded actuator the sensor recognises one single type •1T actuator



### Main features

- Actuation without contact, using RFID technology
- Digitally coded actuator
- Protection degrees IP67 and IP69K
- 4 LEDs for status display of the sensor
- Actuators with various actuation distances

### Quality marks:



UL approval: E496318  
 EC type examination certificate: M6A 075157 0027  
 TÜV SÜD approval: Z10 075157 0026  
 EAC approval: RU C-IT.YT03.B.00035/19

### In compliance with standards:

IEC 61508-1, IEC 61508-2, IEC 61508-3,  
 IEC 61508-4, EN ISO 13849-1, EN ISO 13849-2,  
 EN ISO 14119, EN 62061, EN 60947-5-3,  
 EN 60947-5-2, EN 60947-1, EN 61326-1,  
 EN 61326-3-1, EN 61326-3-2, EN IEC 63000,  
 ETSI 301 489-1, ETSI 301 489-3, ETSI 300 330,  
 UL 508, CSA C22.2 No. 14.

### Compliance with the requirements of:

Machinery Directive 2006/42/EC,  
 EMC Directive 2014/30/EC,  
 Directive 2014/53/EU - RED,  
 RoHS Directive 2011/65/EU,  
 FCC Part 15.

### Connection with safety modules for safety applications:

Connection with safety modules  
 CS AR-01●●●●; CS AR-02●●●●; CS AR-05●●●●;  
 CS AR-06●●●●; CS AR-08●●●●; CS AT-0●●●●●;  
 CS AT-1●●●●●; CS MP●●●●●.

When connected to the safety module, the sensor can be classified as a control circuit device up to PDDb (EN 60947-5-3).

The system can be used in safety circuits up to PL e/SIL 3/category 4 in accordance with EN ISO 13849-1.

## Technical data

### Housing

Housing made of glass fibre reinforced technopolymer, self-extinguishing.  
 Versions with integrated cable 6 x 0.5 mm<sup>2</sup> or 8 x 0.34 mm<sup>2</sup>, length 2 m, other lengths 0.5 m ... 10 m on request  
 Versions with M12 stainless steel connector  
 Versions with 0.1 m cable length and integrated M12 connector, other lengths 0.1 ... 3 m on request  
 Protection degree:

IP67 acc. to EN 60529  
 IP69K acc. to ISO 20653  
 (Protect the cables from direct high-pressure and high-temperature jets)

### General data

SIL (SIL CL) up to: SIL 3 acc. to EN 62061  
 Performance Level (PL) up to: PL e acc. to EN ISO 13849-1  
 Safety category up to: cat. 4 acc. to EN ISO 13849-1  
 Interlock, no contact, coded: type 4 acc. to EN ISO 14119  
 Level of coding acc. to EN ISO 14119: high with SM ●1T actuators  
 low with SM ●0T actuators

Safety parameters:

MTTF <sub>D</sub> :	4077 years
PFH <sub>D</sub> :	1.20E-11
DC:	High
Mission time:	20 years
Ambient temperature for sensors without cable:	-25°C ... +70°C
Ambient temperature for sensors with cable:	see table on page 46
Storage and transport temperature:	-25°C ... +85°C
Vibration resistance:	10 gn (10 ... 150 Hz) acc. to IEC 60068-2-6
Shock resistance:	30 gn; 11 ms acc. to EN 60068-2-27
Pollution degree:	3
Screw tightening torque:	0.8 ... 2 Nm

### Electrical data of IS1/IS2/I3/EDM inputs

Rated operating voltage  $U_{e1}$ : 24 Vdc or 12 ... 24 Vdc  
 Rated current consumption  $I_{e1}$ : 5 mA

### Electrical data of OS1/OS2 safety outputs

Rated operating voltage  $U_{e2}$ : 24 Vdc or 12 ... 24 Vdc  
 Output type: PNP type OSSD  
 Maximum current per output  $I_{e2}$ : 0.25 A  
 Minimum current per output  $I_{m2}$ : 0.5 mA  
 Thermal current  $I_{th2}$ : 0.25 A  
 Utilization category: DC13;  $U_{e2}=24$  Vdc,  $I_{e2}=0.25$  A  
 Short circuit detection: Yes  
 Overcurrent protection: Yes  
 Internal self-resettable protection fuse: 0.75 A  
 Duration of the deactivation impulses at the safety outputs: < 300  $\mu$ s  
 Permissible maximum capacitance between outputs: < 200 nF  
 Permissible maximum capacitance between output and ground: < 200 nF

### Electrical data of O3 signalling output

Rated operating voltage  $U_{e3}$ : 24 Vdc or 12 ... 24 Vdc  
 Output type: PNP  
 Maximum current per output  $I_{e3}$ : 0.1 A  
 Utilization category: DC12;  $U_{e3}=24$  Vdc;  $I_{e3}=0.1$  A  
 Short circuit detection: No  
 Overcurrent protection: Yes  
 Internal self-resettable protection fuse: 0.75 A

### Actuation data

	SMD●T	SM E●T	SM L●T
Assured operating distance $S_{ao}$ :	10 mm	16 mm	10 mm
Assured release distance $S_{ar}$ :	16 mm	27 mm	16 mm
Rated operating distance $S_{ri}$ :	12 mm	20 mm	12 mm
Rated release distance $S_{ri}$ :	14 mm	23 mm	14 mm
Repeat accuracy:	$\leq 10\%$ $s_n$		
Differential travel:	$\leq 20\%$ $s_n$		
RFID transponder frequency:	125 kHz		
Max. switching frequency:	1 Hz		
Distance between two sensors:	min. 50 mm		
Response time upon deactivation of input IS1 or IS2:	typically 7 ms, max. 12 ms		
Response time upon actuator removal:	typically 80 ms, max. 150 ms		

### Power supply electrical data

Rated operating voltage  $U_e$ :

- 24 Vdc versions	24 Vdc -15% ... +10% SELV/PELV
- 12 ... 24 Vdc versions	12 ... 24 Vdc -30% ... +25% SELV/PELV

Operating current at  $U_e$  voltage:

- minimum:	40 mA
- with all outputs at maximum power:	700 mA

Rated insulation voltage  $U_i$ : 32 Vdc  
 Rated impulse withstand voltage  $U_{imp}$ : 1.5 kV  
 External protection fuse: 1 A type Gg or equivalent device  
 Overvoltage category: III



### Features approved by UL

Electrical Ratings: 24 Vdc Class 2, 0,25 A (resistive load)  
 Environmental Ratings: Types 1, 4X, 6, 12, 13  
 Accessory for series ST for actuator switch series SM D, SM E, SM G, SM L.

### Features approved by TÜV SÜD

Supply voltage: 24 Vdc, -15% ... +10%  
 12 ... 24 Vdc -30% ... +25%  
 Protection degree: IP67 and IP69K  
 Ambient temperature: -25°C ... + 70°C  
 Storage and transport temperature: -25°C ... +85°C  
 PL, category: PL e, category 4

In compliance with standards: Machinery Directive 2006/42/EC, EN ISO 13849-1:2015, EN 60947-5-3:2013, EN 61508-1:2010 (SIL 3), EN 61508-2:2010 (SIL 3), EN 61508-3:2010 (SIL 3), EN 61508-4:2010 (SIL 3), IEC 62061:2005 (SIL CL3), IEC 62061:2005/AMD1:2012, IEC 62061:2005/AMD2:2015 (SIL CL3).

Please contact our technical department for the list of approved products.

Please contact our technical department for the list of approved products.

### Selection table for sensors with high level coded actuators

OS safety outputs	O signalling outputs	IS safety inputs	I programming inputs	EDM inputs	Programmable	cable, length: 0.1 m, with M12 connector at the right		cable, length: 0.1 m, with M12 connector at the left		integrated cable, at the right	integrated cable, at the left	M12 connector, at the right	M12 connector, at the left
						ST DD210M0.1-D1T	ST DL210M0.1-D1T	ST DD210N•-D1T	ST DL210N•-D1T	ST DD210MK-D1T	ST DL210MK-D1T		
2	1	-	-	-	-								
2	1	2	-	-	-								
2	1	2	1	-	•								
2	1	2	-	1	-								

To order a product with E•T or L•T actuator replace D with E or L in the codes shown above.  
 For example: ST DD310M0.1-D•T → ST DD310M0.1-E•T or ST DD310M0.1-L•T

### Selection table for sensors

OS safety outputs	O signalling outputs	IS safety inputs	I programming inputs	EDM inputs	Programmable	cable, length: 0.1 m, with M12 connector at the right		cable, length: 0.1 m, with M12 connector at the left		integrated cable, at the right	integrated cable, at the left	M12 connector, at the right	M12 connector, at the left
						ST DD420M0.1	ST DL420M0.1	ST DD420N•	ST DL420N•	ST DD420MK	ST DL420MK		
2	1	2	1	-	•								

### Selection table for actuators

Level of coding acc. to ISO 14119	actuation distance 12 mm	actuation distance 12 mm	actuation distance 20 mm
low	SM L1T	SM D1T	SM E1T

The use of RFID technology in ST series sensors makes them suitable for several applications. Pizzato Elettrica offers two different versions of actuators, in order to best suit customers' specific needs.

Type •0T actuators are all encoded with the same code. This implies that a sensor associated with an actuator type •0T can be activated by other actuators type •0T.

Type •1T actuators are always encoded with different codes. This implies that a sensor associated with an actuator type •1T can be activated only by a specific actuator. Another •1T type actuator will not be recognised by the sensor until a new association procedure is carried out (reprogramming). After reprogramming, the old actuator type •1T will no longer be recognized.

Reprogramming of the actuator can be performed repeatedly.

### Ambient temperature for sensors with cable

Cable features	Connection type	Output with cable		
		N	N	H
Cable type		N	N	H
Conductors		6x0.5 mm <sup>2</sup>	8x0.34 mm <sup>2</sup>	8x0.34 mm <sup>2</sup>
Application field		General	General	General, mobile installation
In compliance with standards		03VV-F	03VV-F	03E7Q-H
Sheath		PVC OIL RESISTANT	PVC OIL RESISTANT	PUR Halogen Free
Self-extinguishing		IEC 60332-1-2 UL 758:FT1 CEI 20-22 II	IEC 60332-1-2 UL 758:FT1 CEI 20-22 II	IEC 60332-1-2 UL 758:FT1 CEI 20-22 II
Oil resistant		UL 758 CSA 22.2 N°210	UL 758 CSA 22.2 N°210	UL 758 CSA 22.2 N°210
Max. speed		/	/	300 m/min.
Max. acceleration		/	/	5 m/s <sup>2</sup>
Minimum bending radius		108 mm	108 mm	70 mm
Outer diameter		7 mm	7 mm	7 mm
End stripped		80 mm	80 mm	80 mm
Copper conductors		Class 6 IEC 60228	Class 5 IEC 60228	Class 6 IEC 60228
Engraving		6272	6276	6283
Ambient temperature	Cable, fixed installation	-25°C +70°C	-25°C +70°C	-25°C +70°C
	Cable, flexible installation	-5°C +70°C	-5°C +70°C	-25°C +70°C
	Cable, mobile installation	/	/	-25°C +70°C
Approvals		CE cULus TÜV EAC	CE cULus TÜV EAC	CE cULus TÜV EAC

→ The 2D and 3D files are available at [www.pizzato.com](http://www.pizzato.com)

### Complete safety system

The use of complete and tested solutions guarantees the electrical compatibility between the sensors of the ST series and the safety modules from Pizzato Elettrica, as well as high reliability. The sensors have been tested with the modules listed in the adjacent table.

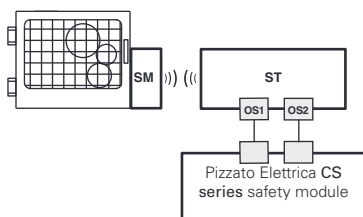

ST sensors can be used as individual devices provided that the outputs be evaluated by a Pizzato Elettrica safety module (see table for combinable safety modules).

### Compatible safety modules

Sensors	Safety modules	Safety module output contacts		
		Instantaneous safety contacts	Delayed safety contacts	Signalling contacts
ST D•••••	CS AR-01•••••	2NO	/	1NC
	CS AR-02•••••	3NO	/	/
	CS AR-05•••••	3NO	/	1NC
	CS AR-06•••••	3NO	/	1NC
	CS AR-08•••••	2NO	/	/
	CS AT-0•••••	2NO	2NO	1NC
	CS AT-1•••••	3NO	2NO	/
	CS MP•••••	see page 369		
	CS MF•••••	see page 401		

All ST series sensors can be connected, provided that compatibility is checked, to safety modules or safety PLCs with OSSD inputs.

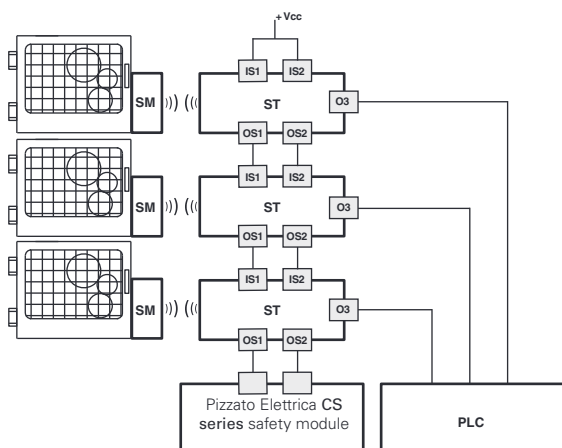

Possibility of series connection of multiple sensors for simplifying the wiring of the safety system, whereby only the outputs of the last sensor are evaluated by a Pizzato Elettrica safety module (see table with compatible safety modules). Each ST sensor is equipped with a signalling output, which – depending on the version – is activated or deactivated when the respective guard is closed. Depending on the specific requirements of the application, this information can be evaluated by a PLC.

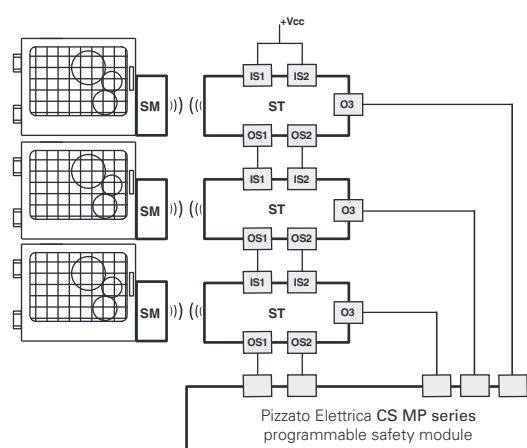

Possibility of series connection of multiple sensors for simplifying the wiring of the safety system, whereby only the outputs of the last sensor are evaluated by a Pizzato Elettrica safety module of the CS MP series. Both the safety-relevant evaluation and the evaluation of the signalling outputs are performed by the CS MP series.

### Internal wiring diagram (ST D•5•••••)

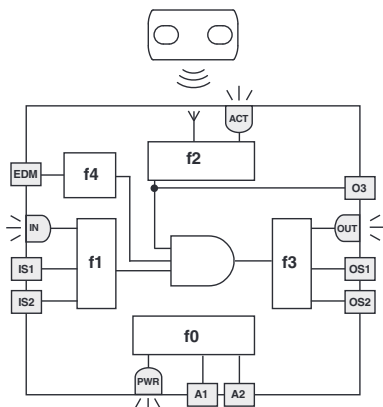

The adjacent diagram illustrates five logical, linked sub-functions of the sensor.

Function f0 is a basic function and includes the monitoring of the power supply as well as internal, cyclical tests.

Function f1 monitors the status of the inputs, whereas function f2 monitors the position of the actuator in the detection area.

Function f3 is intended to activate or deactivate the safety outputs and check for any faults or short circuits in the outputs.

In the EDM versions, function f4 checks the EDM signal on state changes of the safety outputs.

The safety-related function, which combines the sub-functions mentioned above, only activates the safety outputs if the input signals are correctly applied and the actuator is located within the safe zone.

The status of each sub-function is displayed by corresponding LEDs (PWR, IN, ACT, OUT), thereby providing a quick overview of the operating status of the sensor.

LED	Function
ACT	state of actuator / O3 output
IN	status of safety inputs
OUT	status of safety outputs
PWR	Power supply / self-diagnosis



### Limit activation zone and safe activation zone (ST D•4••••)

When aligning the sensor with the actuator, the status LEDs use various colours to indicate whether the actuator is in the limit activation zone or in the safe activation zone. The following figures use the ST DD420MK-D1T sensor as an example.

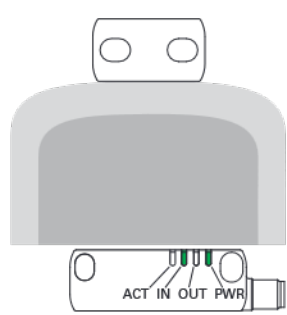

Operating voltage is applied to the sensor, (LED PWR on, green), the inputs are enabled (LED IN on, green), the outputs are deactivated (LED OUT off). The actuator is outside of the actuation zone (LED ACT off).

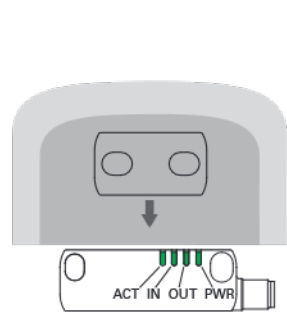

If the actuator is moved inside the safe activation zone (dark grey area), the ACT LED on the sensor illuminates (green) and it activates the outputs (LED OUT on, green).

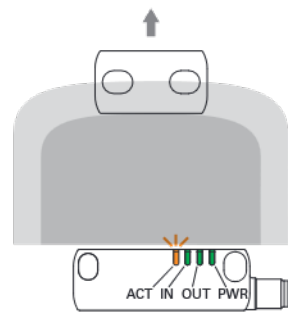

When the actuator leaves the safe zone, the sensor keeps the safety outputs enabled. Entry into the limit activation zone (light grey area) is, however, indicated by the ACT LED (orange/green, flashing).

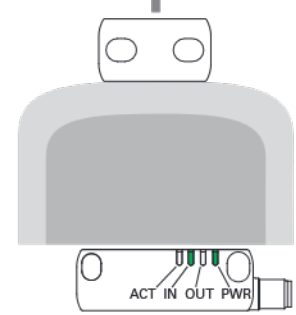

As soon as the actuator exits the limit activation zone, the sensor deactivates the outputs and switches off the OUT and ACT LEDs.

### Operating states (ST D•4••••)

PWR LED	OUT LED	IN LED	ACT LED	Sensor state	Description
○	○	○	○	OFF	Sensor off.
●	○	○	○	POWER ON	Internal tests upon activation.
●	*	○	*	RUN	Sensor with inactive inputs.
●	*	●	*	RUN	Activation of the inputs.
●	*	◌	*	RUN	Input incoherence. Recommended action: check for presence and/or wiring of inputs.
●	*	*	●	RUN	Actuator in safe area. O3 signalling output active.
●	*	*	◌	RUN	Actuator in limit activation zone, O3 active. Recommended action: bring the sensor back to the safe area.
●	●	●	●	RUN	Activation of the inputs. Actuator in safe area and safety outputs active.
●	◌	*	*	ERROR	Error on outputs. Recommended action: check for any short circuits between the outputs, outputs and ground or outputs and power supply, then restart the sensor.
●	*	*	*	ERROR	Internal error. Recommended action: restart the sensor. If the failure persists, replace the sensor.

Legend: ○ = off ● = on ◌ = flashing ◐ = alternating colours \* = indifferent

### External device monitoring (EDM)

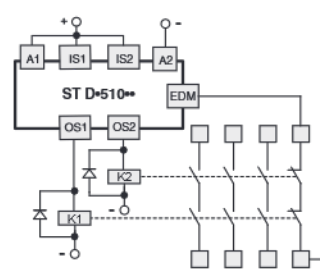

The ST D•51••• version, in addition to maintaining the operating and safety characteristics of the ST series, allows control of **forcibly guided NC contacts of contactors or relays** controlled by the safety outputs of the sensor itself. As an alternative to the relays or contactors you can use Pizzato Elettrica expansion modules CS ME-03. See page

359.

This check is carried out by monitoring the EDM input (External Device Monitoring as defined in EN 61496-1) of the sensor.

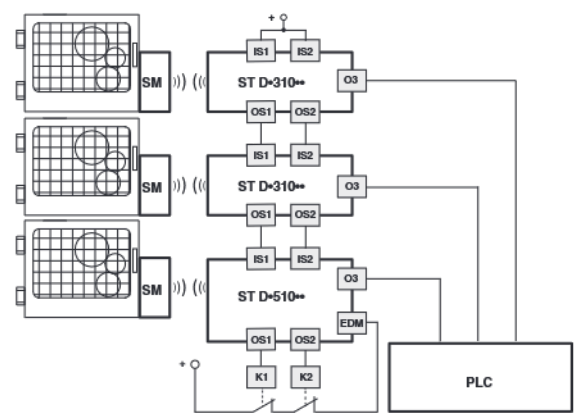

This version, with the IS safety inputs, **can be used at the end of a series of ST sensors, up to a maximum number of 32 devices**, while maintaining the maximum PL e safety level according to EN ISO 13849-1.

For specific applications, this solution allows you to dispense with the safety module connected to the last device in the chain.

### O3 output inverted (ST D•6••••, ST D•7••••, ST D•8••••)

The version with inverted O3 signalling output allows checking of the actual electrical connection of the sensor by an external PLC. The O3 output will be activated when the actuator is removed and the OS safety outputs are switched off.

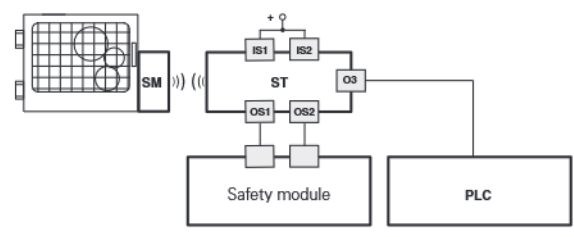



## Connection with safety modules

Connections with CS AR-08•••• safety modules

Input configuration with monitored start  
2 channels / Category 4 / up to SIL 3 / PL e

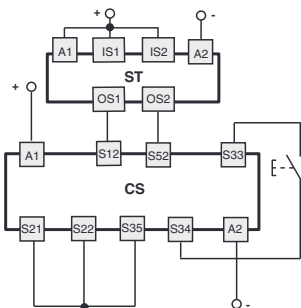

Connections with CS AT-0••••• / CS AT-1••••• safety modules

Input configuration with monitored start  
2 channels / Category 4 / up to SIL 3 / PL e

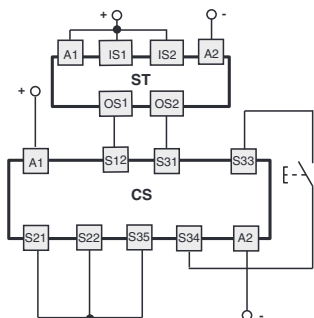

For features of the safety modules see page 305.

Connections with CS AR-05••••• / CS AR-06••••• safety modules

Input configuration with manual start (CS AR-05•••••)  
or monitored start (CS AR-06•••••)

2 channels / Category 4 / up to SIL 3 / PL e

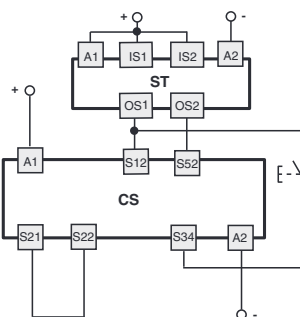

Connection with safety module CS MP•••••0

The connections vary according to the program of the module  
Category 4 / up to SIL 3 / PL e

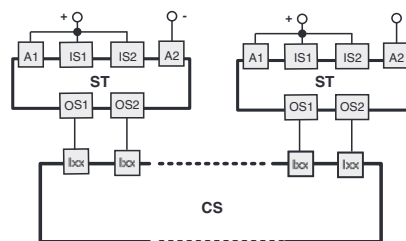

For application examples, see page 368.

## Internal device connections

### 5-pole versions

ST D•2•••••, ST D•6•••••

M12 connector	Cable	Connection
1	brown	A1 (+)
2	red/white	OS1
3	blue	A2 (-)
4	black/white	OS2
5	black	O3
/	red	not connected

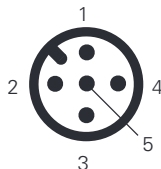

### 8-pole versions

ST D•3•••••, ST D•4•••••, ST D•5•••••, ST D•7•••••, ST D•8•••••

M12 connector	Cable	Connection
1	brown	A1 (+)
2	red	IS1
3	blue	A2 (-)
4	red/white	OS1
5	black	O3
6	purple	IS2
7	black/white	OS2
8	purple/white	not connected <sup>(a)</sup> I3 <sup>(b)</sup> EDM <sup>(c)</sup>

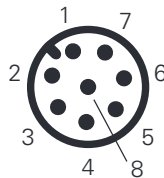

<sup>(a)</sup> for articles ST D•3•••••, ST D•7•••••.  
<sup>(b)</sup> for articles ST D•4•••••, ST D•8•••••.  
<sup>(c)</sup> for articles ST D•5•••••.

### Legend:

- A1-A2: supply
- IS1-IS2 Safety inputs
- OS1-OS2: safety outputs
- O3: signalling output
- I3: programming input
- EDM: input for monitoring of NC contacts of the contactors

**Note:** Versions with customised pin assignments are available on request.

For female connectors, see page 419.

## Series connection

To simplify series connections of the devices, various M12 connectors are available that allow complete wiring.

This solution significantly reduces installation times while at the same time maintaining the maximum safety levels PL e and SIL 3.

For further information see page 426.

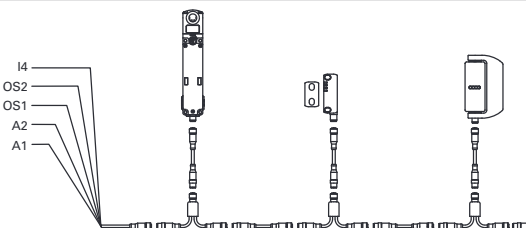



### Operating distances SM D•T/SM L•T actuators

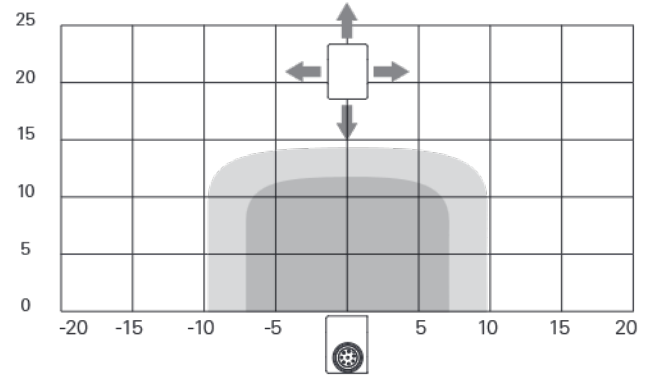
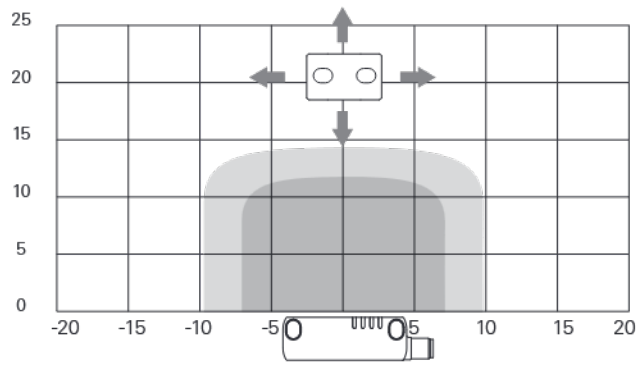

### Operating distances SM E•T actuator

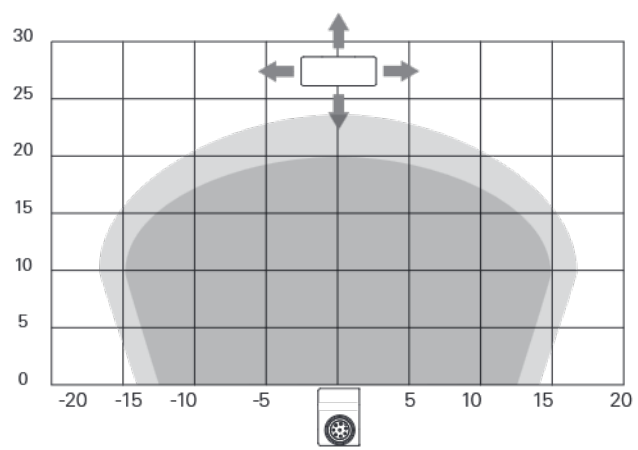
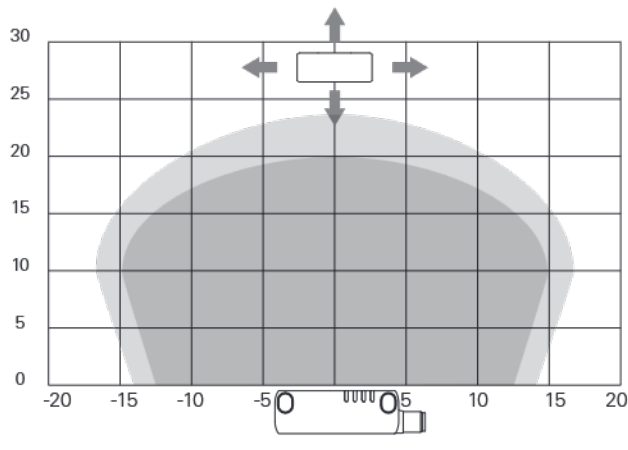

Legend:

- Rated operating distance  $s_n$  (mm)
- Rated release distance  $s_m$  (mm)

**Note:** The progress of the activation areas is for reference only; the possible application on ferromagnetic surfaces can reduce the operating distances.

### Dimensional drawings

ST DD•••N• sensor with cable at the right

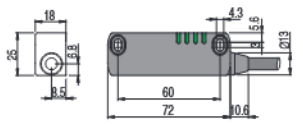

ST DD•••MK sensor with M12 connector at the right

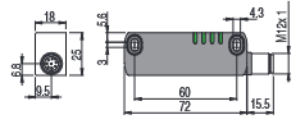

ST DD•••M0.1 sensor with cable and M12 connector at the right

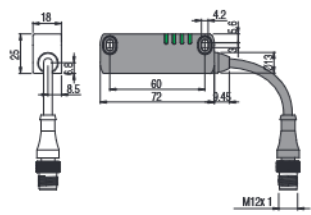

ST DL•••N• sensor with cable at the left

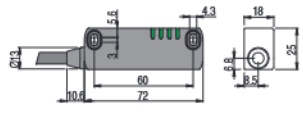

ST DL•••MK sensor with M12 connector at the left

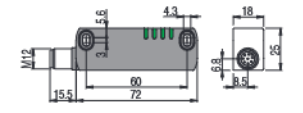

ST DL•••M0.1 sensor with cable and M12 connector at the left

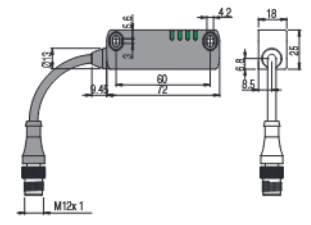

SM D•T actuator

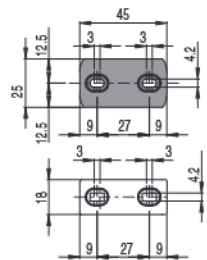

SM E•T actuator

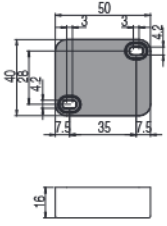

SM L•T actuator

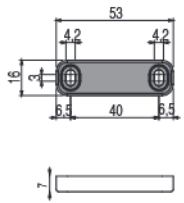

All values in the drawings are in mm

Accessories See page 419

→ The 2D and 3D files are available at [www.pizzato.com](http://www.pizzato.com)

