

Capacity up to 300 kg

DESCRIPTION

- ABS crane scale with upper swivel shackle and lower swivel hook.
- 5-digit backlit LCD display (20 mm height).
- 4 signalling symbols.
- IP54 protection rating.
- 4 batteries 1.5 V AA type included.
- Operating time: 80 hours.
- Remote control with range up to 10 m line of sight.

MAIN FUNCTIONS

- Weight zero setting.
- Tare weight zero setting.
- Reading division setting.
- Units of measure setting: kg - lb.
- Auto power-off.



CAPACITY	kg	DIVISION (g)	NET WEIGHT (kg)	CODE
	50	e=10	1.2	DTEP50
	150	e=20	1.2	DTEP150
	300	e=50	1.2	DTEP300

CERTIFICATIONS

UK Equivalent of the CE marking for the United Kingdom

CA

CERTIFICATIONS ON REQUEST

Calibration report

DIMENSIONS (mm)

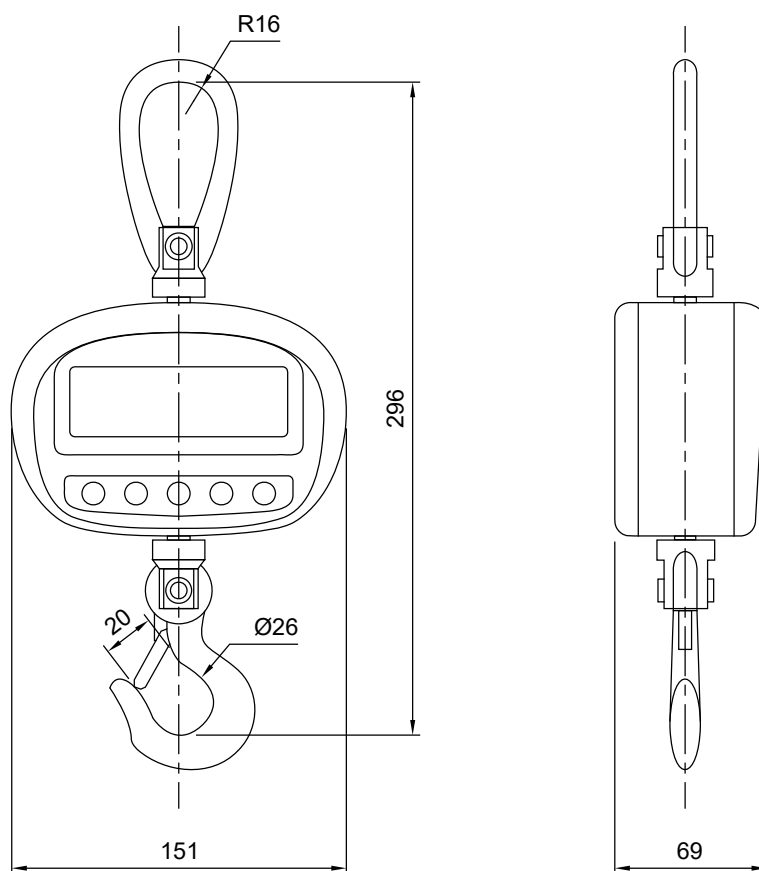

TECHNICAL FEATURES

Accuracy class (% of full scale)	± 0.05%
Safe overload (% of full scale)	150%
Ultimate overload (% of full scale)	200%
Humidity (condensate free)	10÷90%
Working temperature	-10°C +40°C