

Programmable Logic Relays

8A
SERIES



Panels for electrical distribution



Packaging machines



Control and management of water



Control panels for pumps



Air Conditioner



Building automation



Forced-air ventilators



Programmable Logic Relays (PLRs) with 8 input and 4 output relays

Type 8A.04-8300

- Lite version with USB (type C port), ETH

Type 8A.04-8310

- Plus version with USB (type C port), ETH and Modbus RS485

Type 8A.04-8320

- Advanced version with USB (type C port), ETH, Modbus RS485, Wi-Fi and BLE

- 8 digital or analog (0...10V) input
- 4 relay output 10 A
- USB (type C port) port for programming, data logging and powering during configuration
- RJ45 port
- Connectivity (*according to type):
 - USB
 - 1 Gbit Ethernet TCP/IP or Modbus TCP/IP
 - Modbus RS485*
 - Wi-Fi + BLE*
- LED status indicator for each output
- Programmable USER button
- Programming language via IDE as an option IEC-61131-3 (LD - SFC - FBD - ST - IL)
- 70 mm wide
- 35 mm rail (EN 60715) mount

8A.04
Box clamp



For outline drawing see page 12

Output specification

Contact configuration		4 NO (SPST)
Rated current/Maximum peak current	A	10/15
Rated voltage/ Maximum switching voltage	V AC	250/400
Rated load AC1	VA	2500
Rated load AC15 (230 V AC)	VA	500
Breaking capacity DC1: 24/110/220 V	A	10/0.3/0.12
Minimum switching load	mW(V/mA)	300 (5/5)
Output operate/release time	ms	6/4
Standard contact material		AgNi

Input circuit

Number of inputs		8
Type		Digital/Analog (configurable)
Analog input type	V	0...10
Analog input resolution		16 to 12 bit user configurable
Input frequency	kHz	4.5
Input voltage	signal 0/signal 1	< 4 V DC / > 5.9 V DC (Max. 24 V DC)
Maximum input voltage	V DC	24
Input compatibility		PNP/NPN/Sink
Reverse polarity protection		YES

Supply specification

Nominal voltage (U _N)	V DC	12...24
Rated power	W	0.6...2.2 (according to type)
Operating range	V DC	10.2...27.6

Technical data

Programming language		Arduino IDE, IEC-61131-3 (LD - SFC - FBD - ST - IL) via Arduino PLC-IDE
Minimum input signal	ms	0.2
Electrical life at rated load in AC1	cycles	100 · 10 ³
Ambient temperature range	°C	-20...+50
Protection category		IP 20

Approvals (according to type)

8A.04-8300



- Lite version
- USB Port
- RJ45 Port for ETH and Modbus TCP/IP

8A.04-8310



- Plus version
- USB Port
- RJ45 Port for ETH and Modbus TCP/IP
- Modbus RS485 Port

8A.04-8320



- Advanced version
- USB Port
- RJ45 Port for ETH and Modbus TCP/IP
- Modbus RS485 Port
- Wi-Fi/BLE internal module



Partnership with



H

Expansion modules

Type 8A.58-1600

- 16 digital or analog (0...10 V) inputs
- 8 EMR 6 A outputs

Type 8A.88-1600

- 16 digital or analog (0...10 V) inputs
- 8 SSR 3 A outputs

- LED power status indicator
- 8 output status LEDs
- Auxiliary port
- Up to 5 expansion modules connectable
- Programming language via Arduino IDE or via Arduino PLC-IDE for IEC 61131-3 languages (LD - SFC - FBD - ST - IL)
- 70 mm wide
- 35 mm rail (EN 60715) mount

8A.58/8A.88
Box clamp



8A.58-1600



8A.88-1600



- 16 digital/analog (0...10 V) inputs
- 8 EMR 6 A outputs
- Nominal voltage 12...24 V DC

- 16 digital/analog (0...10 V) inputs
- 8 SSR 3 A outputs
- Nominal voltage 12...24 V DC



OEM PROJECTS



BUILDING AUTOMATION



INDUSTRIAL APPLICATIONS

OPTA

Partnership with



For outline drawing see page 12

Output specification

Contact configuration		8 NO (SPST)	8 NO (SPST)
Rated current/Maximum peak current	A	6/10	3/50
Rated voltage/ Maximum switching voltage	V	250/400 V AC	24/33 V DC
Switching voltage range	V DC	—	1.5...30
Rated load AC1	VA	1500	—
Rated load AC15 (230 V AC)	VA	300	—
Rated load DC13	W	—	36
Minimum switching current	mA	—	1
Breaking capacity DC1: 24/110/220 V	A	6/0.2/0.12	—
Minimum switching load	mW (V/mA)	500 (12/10)	—
Max "OFF-state" leakage current	mA	—	0.001
Max "ON-state" voltage drop	V	—	0.4
Output operate/release time	ms	6/4	0.02/0.2
Standard contact material		AgNi	—

Input circuit

Number of inputs		16	
Type		Digital/analogue	
Analog input type	V	0...10	
Analog input resolution		configurable 12 bit Max. - 8 bit Min.	
Input frequency	kHz	4.5	
Input voltage	signal 0/signal 1	< 4 V / > 5.9 V DC (Max. 24 V DC)	
Maximum input voltage	V DC	24	
Input compatibility		PNP/NPN	
Reverse polarity protection		YES	

Supply specification

Nominal voltage (U _N)	V DC	12...24	
Rated power	W	1	
Operating range	V DC	10.6...27.5	

Technical data

Programming language		ARDUINO IDE or ARDUINO PLC-IDE (IEC 61131-3 languages)	
Minimum input signal	ms	0.02	
Electrical life at rated load in AC1	cycles	60 · 10 ³	> 10 ⁶
Ambient temperature range	°C	-20...+50	
Protection category		IP 20	

Approvals (according to type)



Expansion modules

Type 8A.26-0600

- 6 analog inputs 0...10 V, 4...20 mA, PT 100 (2-3 wires)
- 2 analog outputs 0...10 V, 4...20 mA
- 4 PWM outputs
- Nominal voltage 12...24 V DC
- LED power status indicator
- 8 programmable LEDs
- Auxiliary port
- Up to 5 expansion modules connectable
- Programming language via Arduino IDE or via Arduino PLC-IDE for IEC 61131-3 languages (LD - SFC - FBD - ST - IL)
- 70 mm wide
- 35 mm rail (EN 60715) mount

For outline drawing see page 12

Analog outputs specification

Number of analog outputs 2 (programmable up to 8)

Type of analog outputs Analog voltage 0...10 V and current 4...20 mA

Analog outputs resolution bit 13

Voltage output mode

Analog output voltage V DC 0...10

Short-circuit current per channel (sourcing) mA Min. 25 - Max. 32

Short-circuit current per channel (sinking) mA Min. 3.0 - Max. 4.5

Accuracy +/- 1 %

Repeatability +/- 1 %

Current output mode

Analog output current mA 0/4...20

Maximum output voltage @ 20 mA V 11.9 ± 20%

Open circuit voltage V 16.9 ± 20%

Output impedance MΩ Min. 1.5 - Max. 4

Accuracy 1% in 0...10 mA range, 2% in 10...20 mA range

Repeatability 1% in 0...10 mA range, 2% in 10...20 mA range

PWM output channels

Number of PWM outputs 4

Source voltage supported V DC 8...28.8

PWM frequency kHz 10

Max current mA 100

Period Programmable

Duty-cycle Programmable (0-100%)

Input analog specification

Number of analog inputs 6 (programmable up to 8)

Type of analog inputs Analog voltage 0...10 V, current 4...20 mA, PT100

Inputs overvoltage protection Yes (Up to 40 V)

Antipolarity protection No

Analog Input resolution bit 16

Voltage Input Mode

Analog input voltage V 0...10

Input impedance MΩ Min. 175

Accuracy +/- 1 %

Repeatability +/- 1 %

Current Input Mode

Analog input current mA 0/4...20

Short circuit current limit mA Min. 25 - Max 35

Programmable current limit mA 0.5...24.5

Accuracy +/- 1 %

Repeatability +/- 1 %

RTD Input Mode

RTD input type PT 100

Wiring type (Input) 2 wires (I1...I6, O1, O2)

3 wires (I1, I2)

Input range MΩ 0...1

Bias voltage V 2.5

Temperature range °C -25...+400

Accuracy +/- 1.5 °C (in the ambient T range -20°C...50°C)

Supply specification

Nominal voltage (U_N) V DC 12...24

Rated power W 1

Operating range V 9.6...28.8

Technical data

Programming language Via OPTA main module through ARDUINO IDE or ARDUINO PLC-IDE

LED signaling 1 power LED + 8 user programmable LEDs

Ambient temperature range °C -20...+50

Protection category IP 22

Approvals (according to type)

NEW 8A.26-0600



- 6 analog inputs 0...10 V, 4...20 mA, PT100 (2-3 wires)
- 2 analog outputs 0...10 V, 4...20 mA
- 4 PWM outputs
- Nominal voltage 12...24 V DC

Ordering information

Example: 8A Series, Lite PLR version, 4 NO (SPST) - 10 A, 8 digital/analog inputs, 12...24 V DC.

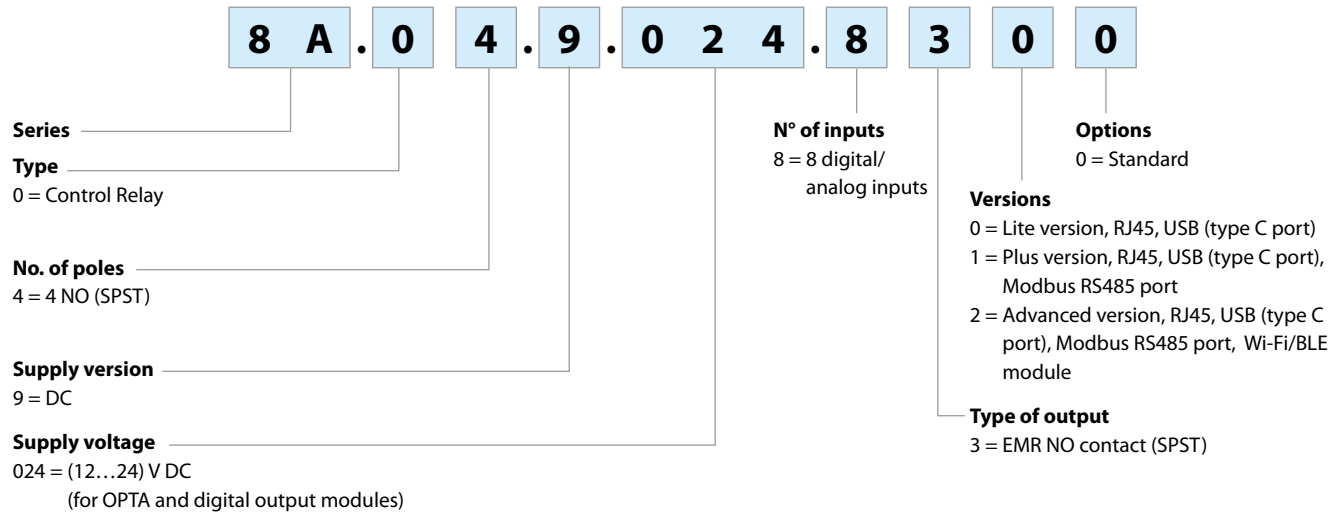

Example: 8A Series, digital EMR expansion, 8 EMR outputs - 6 A, 16 digital/analog inputs, supply 12...24 V DC.

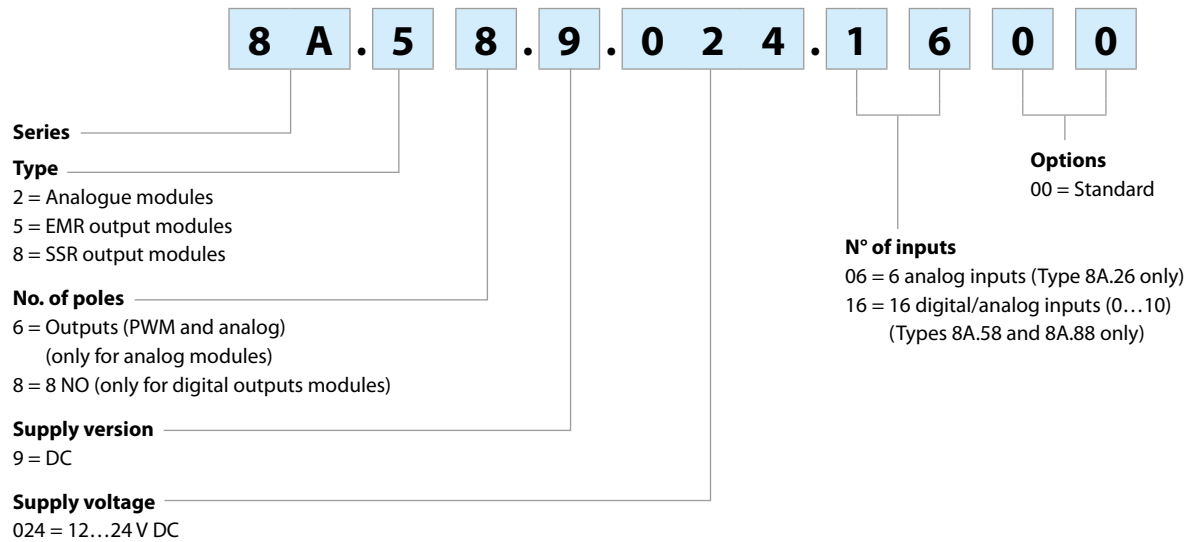

Technical data

Insulation				
	between input and output circuit	V AC	4000	
	between open contacts	V AC	1000	
Insulation (1.2/50 μs) between input and output		kV	6	
EMC specifications				
Type of test		Reference standard		
Electrostatic discharge	contact discharge	EN 61000-4-2	4 kV	
	air discharge	EN 61000-4-2	8 kV	
Radio-frequency electromagnetic field (80 ÷ 1000 MHz)		EN 61000-4-3	10 V/m	
Fast transients (burst) (5-50 ns, 5 kHz) on Supply terminals		EN 61000-4-4	4 kV	
Surges (1.2/50 μs) on Supply terminals	common mode	EN 61000-4-5	4 kV	
	differential mode	EN 61000-4-5	4 kV	
	on input terminals	common mode	EN 61000-4-5	4 kV
	differential mode	EN 61000-4-5	4 kV	
Radio-frequency common mode (0.15 ÷ 80 MHz) on Supply terminals		EN 61000-4-6	10 V	
Radiated and conducted emission		EN 55022	class B	
Other data				
Power lost to the environment	without contact current	W	1.4	
	with rated current	W	3.2	
PLC to PLC communication and PLC to network communication (Ethernet)		Ethernet: – For Modbus TCP communication – As standard TCP/IP – RJ45 connector CAT5 cable, 2X LAN status led indicators RS485: – For Modbus RTU communication – For custom serial communication		
Wireless connectivity		Wi-Fi and Bluetooth® Low Energy		
Maximum program memory		1 MB internal		
External memory module		USB-C pendrive		
Data Logging		USB-C Stick + internal flash memory		
Flash memory		2MB int + 16MB Flash QSPI		
RESET button		YES		
USER button		Push button configurable for user purposes		
MCU		STMicroelectronics STM32H747XI Dual ARM® Cortex® M7/M4 IC: 1x ARM® Cortex® -M7 core up to 480 MHz 1x ARM® Cortex® -M4 core up to 240 MHz		
Secure element		ATECC608B		
Programming interface		USB-C + OTA via Web Editor (Cloud) + Ethernet		
RTC power reserve		10 days at 25 °C		
RTC accuracy		10 min/year @25 °C 37.5 min/year @ -10...+70 °C		
Cloud support		Arduino Cloud via Wi-Fi and Ethernet or the Cloud services		
Response time ON/OFF		ms	6/4	
Bounce time NO/NC		ms	3/6	
Terminals		Box clamp		
Wire strip length		mm	9	
Screw torque		Nm	0.5	
Min. wire size		solid cable	stranded cable	
	mm ²	0.5	0.5	
	AWG	20	20	
Max. wire size		solid cable	stranded cable	
	mm ²	1 x 2.5 / 2 x 1.5	1 x 2.5 / 2 x 1	
	AWG	1 x 14 / 2 x 16	1 x 14 / 2 x 16	

H

Front view - Type 8A.04.9.024.8310

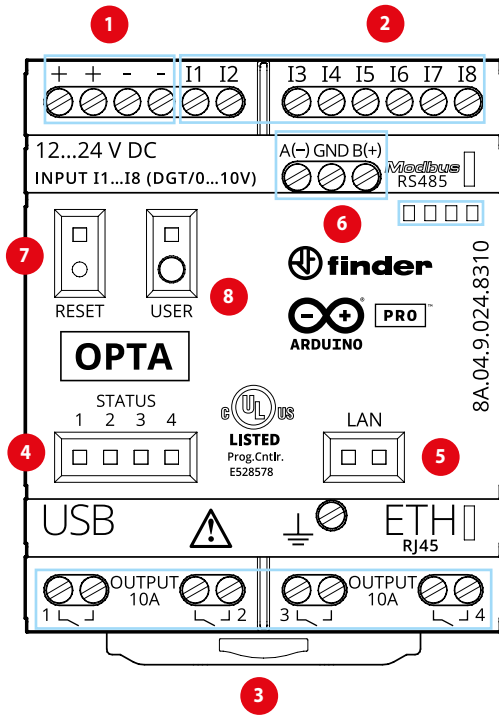

- 1 Supply terminals**
12...24 V DC, Split terminals to facilitate wiring.

- 2 Input terminals**
11...18 digital/analog (0...10 V) input configurable via IDE.

- 3 Output terminals**
1...4 Output relay, 10 A - 250 V AC, NO contact.

- 4 LED Status**
1...4 LED Status configurable via IDE.
For example for 1...4 output relay LED ON = Contact CLOSE.

- 5 LED Ethernet port status**
Status of ETH connection.

- 6 Modbus RS485 Port**
Terminals for Modbus over RS485 protocol.

- 7 HARDWARE RESET**
Button for hardware reset. BE CAREFUL. Press the 'RESET' button with the tip of a small non-metallic insulated tool.

- 8 Programmable USER button**
Button configurable via IDE by user, according to application (ex. RUN/STOP, ON/OFF, BLE pair).

Front view - Digital EMR - Type 8A.58.9.024.1600

H

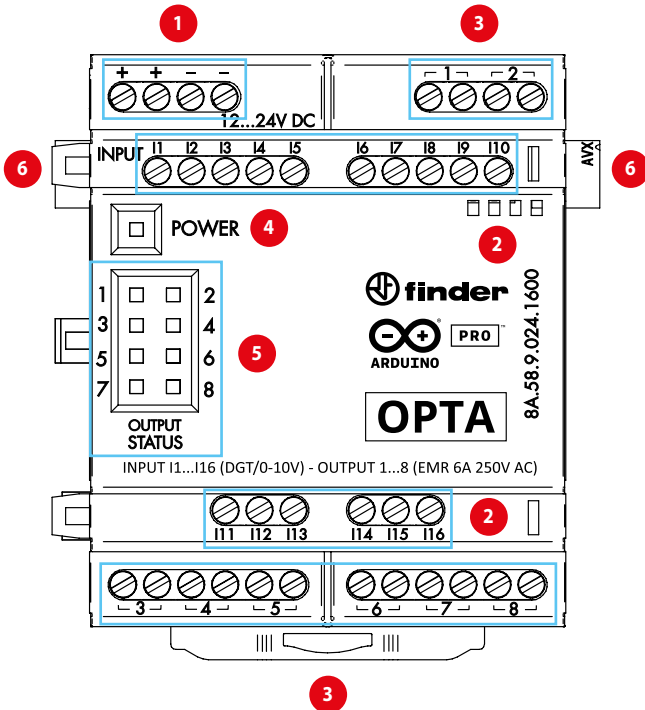

- 1 Supply terminals**
12...24 V DC, Bifurcated terminals

- 2 Input terminals**
11...116 digital/analog (0...10 V) input configurable via IDE.

- 3 EMR Output terminals**
1...8 EMR output, 6 A - 250 V AC

- 4 LED Status**
LED RGB

- 5 Output status LED**
Yellow LED output status

- 6 AUXILIARY PORT**

Front view - Digital SSR - Type 8A.88.9.024.1600

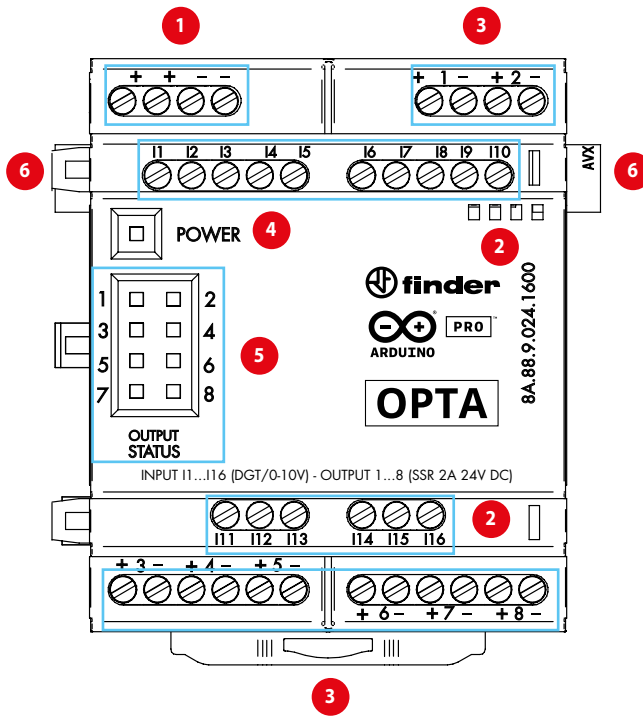

- 1 **Supply terminals**
12...24 V DC, Bifurcated terminals
- 2 **Input terminals**
I1...I16 digital/analog (0...10 V) input configurable via IDE.
- 3 **SSR Output terminals**
1...8 SSR output, 3 A - 24 V DC
- 4 **LED Status**
LED RGB
- 5 **Output status LED**
Yellow LED output status
- 6 **AUXILIARY PORT**

Front view - Analogue - Type 8A.26.9.024.1600

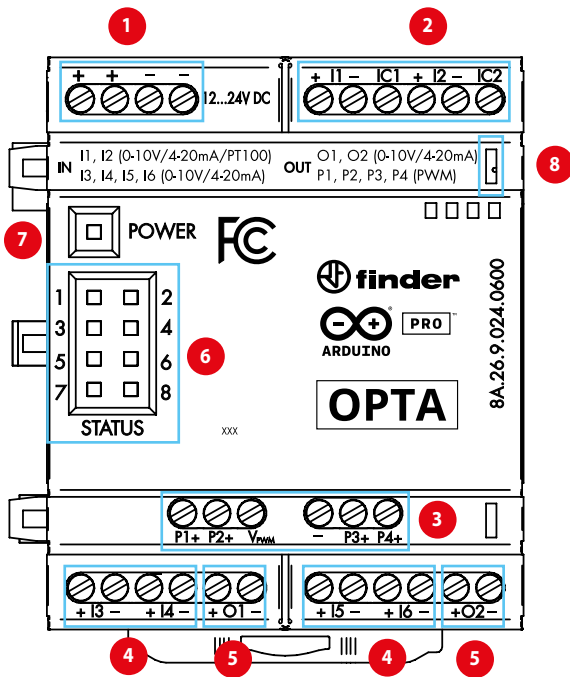

- 1 **Supply terminals**
12...24 V DC, Bifurcated terminals
- 2 **Input terminals**
I1,I2 Analog input 0...10 V, 0/4...20 mA, PT100 (2 or 3 wires)
- 3 **PWM Output terminals**
P1...P4 PWM positive output terminals, V_{_pwm} voltage PWM terminal, - negative PWM terminal
- 4 **Input terminals**
I3...I6 Analog input 0...10 V, 0/4...20 mA, PT100 (2 wires)
- 5 **Output terminals**
O1, O2 Analog output 0...10 V, 0/4...20 mA
- 6 **Output status LED**
Yellow programmable status LED
- 7 **Power LED status**
LED RGB
- 8 **AUXILIARY PORT**

H

Wiring diagrams

Type 8A.04-8300

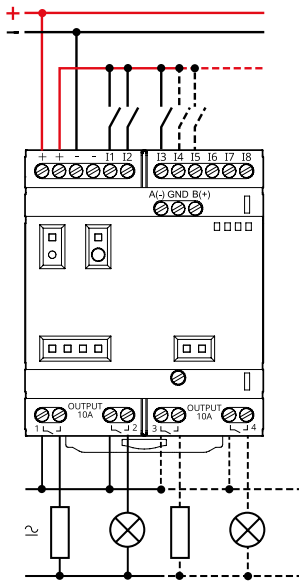

Type 8A.04-8310/8320

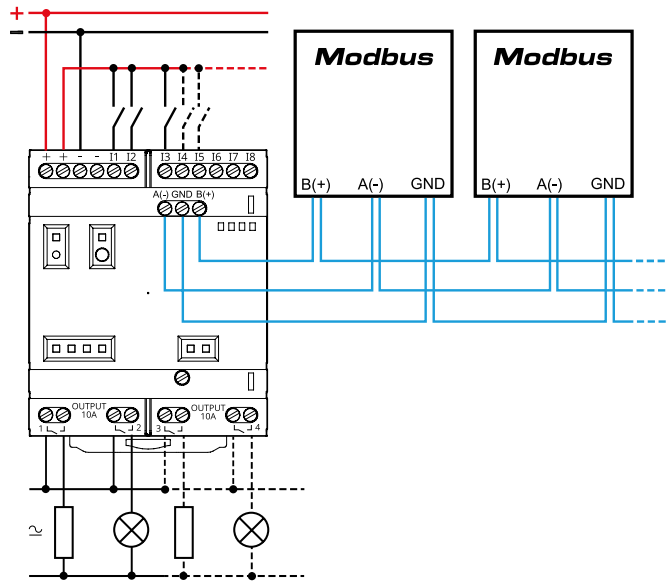

Type 8A.58-1600

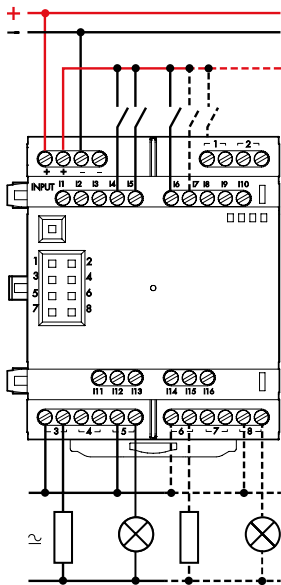

Type 8A.88-1600

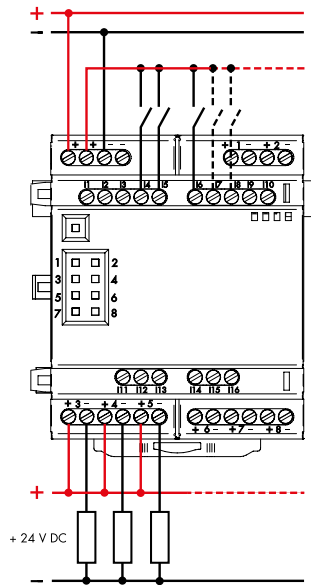

Type 8A.26-0600

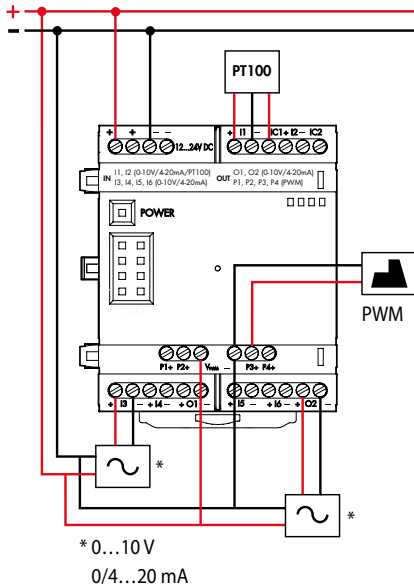

Contact specification

F 8A - Electrical life (AC) v contact current

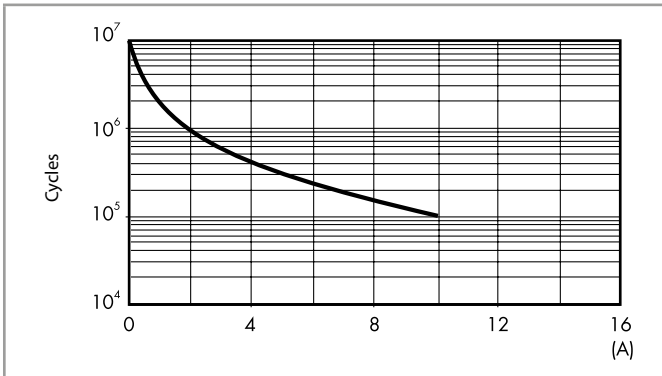

H 8A - Maximum DC1 breaking capacity

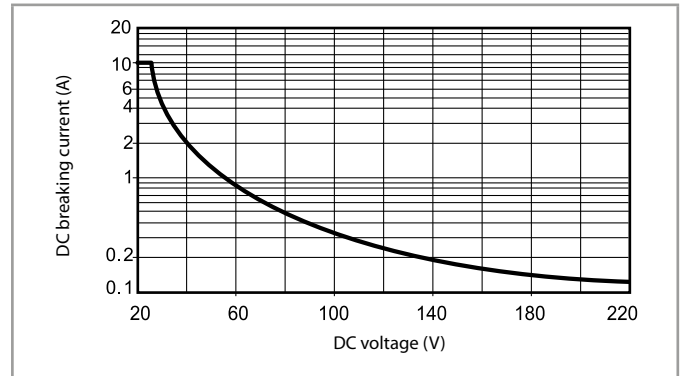

- When switching a resistive load (DC1) having voltage and current values under the curve, an electrical life of $\geq 100 \cdot 10^3$ can be expected.
- In the case of DC13 loads, the connection of a diode in parallel with the load will permit a similar electrical life as for a DC1 load. Note: the release time for the load will be increased.

Getting "Started Guide"

GETTING STARTED GUIDE: <https://docs.arduino.cc/hardware/opta/>

If you want to program your OPTA while offline you need to install the Arduino Desktop IDE, Arduino Cloud or Arduino PLC-IDE.

To connect the OPTA to your computer, you'll need a USB cable.

<https://www.arduino.cc/en/Main/Software>

GETTING STARTED - ARDUINO CLOUD

All Arduino IoT enabled products are supported on Arduino Cloud which allows you to Log, graph and analyze sensor data, trigger events, and automate your home or business.

The Arduino Cloud is hosted online, therefore it will always be up-to-date with the latest features and support for all boards.

Follow to start coding on the browser and upload your sketches onto your board.

<https://cloud.arduino.cc>

Outline drawings

Type 8A.04-8300
Box clamp

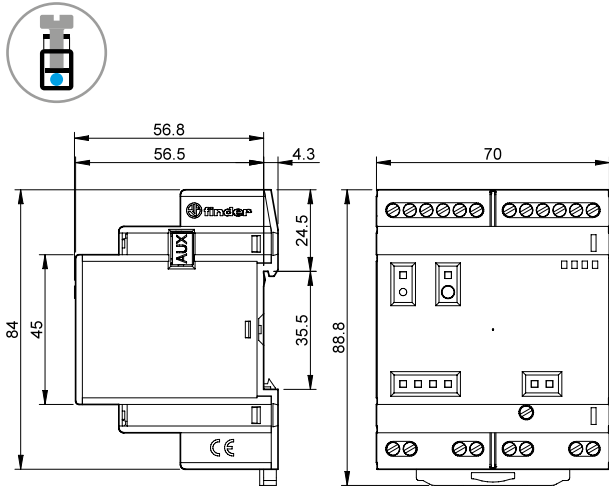

Type 8A.04-8310/8320
Box clamp

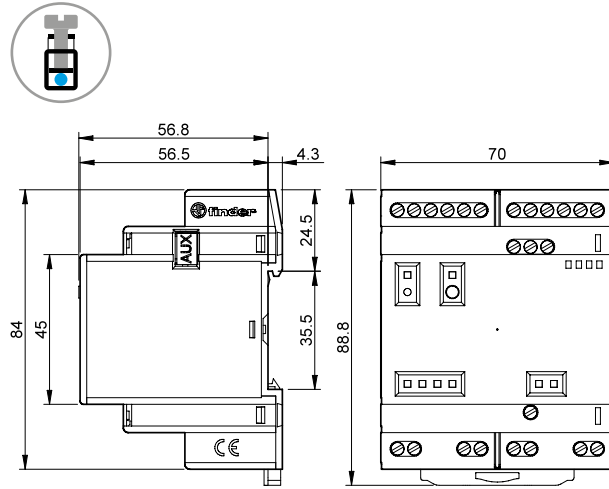

Type 8A.58-1600
Box clamp

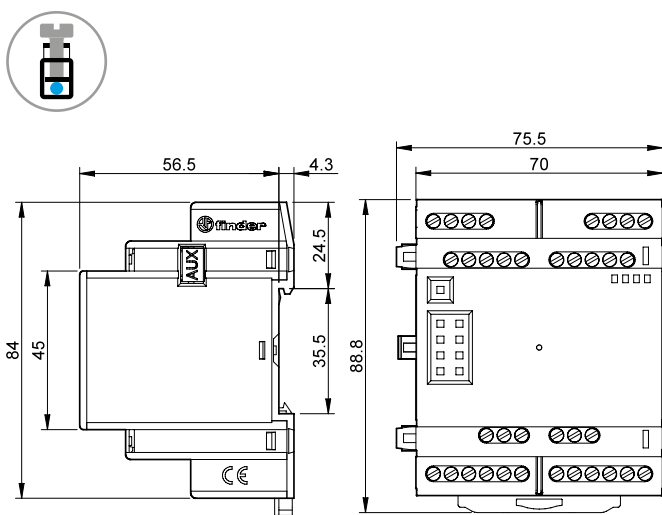

Type 8A.88-1600
Box clamp

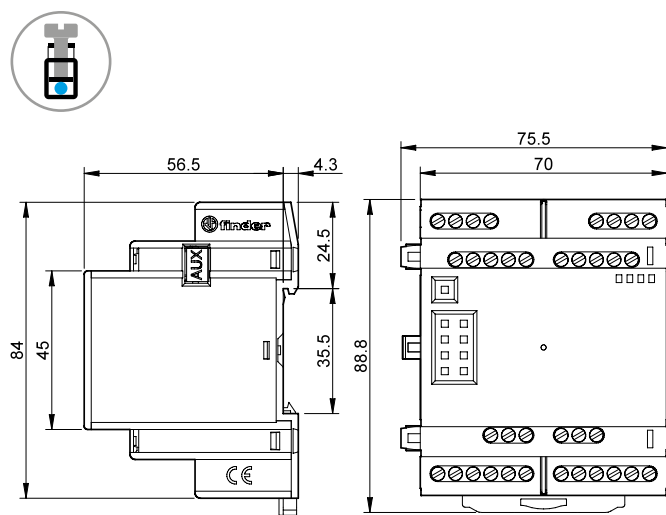

Type 8A.26-0600
Box clamp

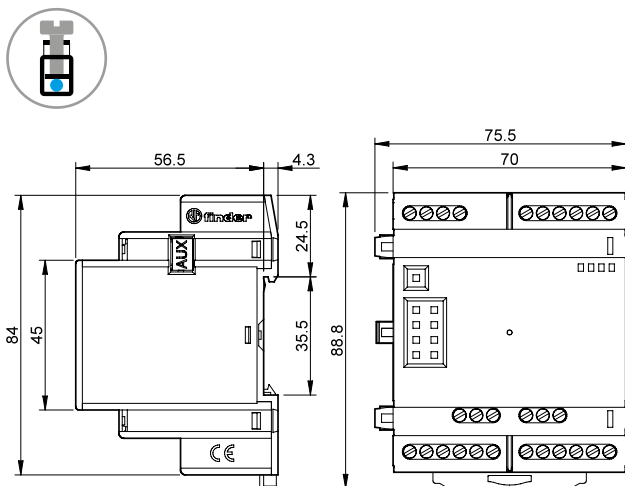

H